



MULTIFUNCTIONAL GAMMA MONITOR MFM 203

USER MANUAL

Ljubljana, 2004

AMES d.o.o., Jamova 39, SI-1000 Ljubljana, Slovenia
Post address: Na Lazih 30, SI-1351 Brezovica, Slovenia
tel. +386 1 365 71 01 fax +386 1 365 71 02
EMAIL: info@ames.si <http://www.ames.si>

ARIES

1. DESCRIPTION	4
1.1 INTRODUCTION	4
1.2 FUNCTIONS.....	4
1.3 HIGHLIGHTS	5
1.4 MEASUREMENT PROCEDURE.....	6
2. TECHNICAL SPECIFICATIONS	7
3. INSTALLATION	9
3.1 INSTALLATION OF GM PROBES.....	10
3.2 GROUNDING THE SYSTEM.....	12
3.3 CONNECTING CABLES	13
4. OPERATING INSTRUCTIONS	15
4.1 INTERNAL POWER SUPPLIES	15
4.2 TURNING THE INSTRUMENT ON / OFF.....	16
4.3 USING KEYBOARD AND MENU.....	17
4.4 MEASUREMENT DISPLAY	18
4.4 MEASUREMENT DISPLAY	19
4.5 DATA LISTING.....	20
4.5.1 Dose	20
4.5.2 Counts.....	21
4.5.3 Event list	22
4.5.4 Interval list.....	23
4.5.3 Rain interval list	25
4.6 MANUAL PRINTING OF DATA	26
4.6.1 Print last N events.....	26
4.6.2 Print last N intervals.....	26
4.6.3 Print parameters.....	26
4.7 CHANGING OF PARAMETERS	27
4.7.1 System time set.....	27
4.7.2 System reset	28
4.7.3 Sound setting	29
4.7.4 Display back light settings.....	30
4.7.5 Communication parameters.....	31
4.7.6 Printer parameters	32
4.7.7 Unit number.....	33
4.7.8 User type.....	33
4.7.9 Radiological parameters	34
4.7.10 Rain parameters	36
4.7.11 Power supply parameters	36
4.8 DATA TRANSMISSION.....	37
4.8.1 Connection.....	37
4.8.2 Instant data	38
4.8.3 Last interval data.....	39
4.8.4 Any stored interval data.....	39
4.8.5 Parameters	41
4.8.6 Time	42
4.8.7 Internal log file	42



1. DESCRIPTION

1.1 INTRODUCTION

MFM 203 is a portable-size instrument designed for continuous monitoring of gamma radiation in the environment. It autonomously performs all the necessary functions of a self-sustained local monitor. When connected to a data communication link, it can serve as an intelligent field unit of the real-time early warning network. Supplied with two energy-compensated GM probes of different sensitivities, it can cover dose-rates from the normal background to the accidental levels.

The microprocessor-controlled monitor is equipped with a keyboard and a Liquid Crystal Display. Unit autonomously processes, displays and prints (printer is an option) all measured data and warnings and triggers visual and sound alarms. It is designed to be connected on-line (via a modem and telephone line or radio link) to the central data collecting and controlling computer of an early warning system. Data can be transferred in real time or at scheduled time intervals.

In the standard version the instrument consists of the following components:

- MFM 203 processor unit
- remote “A” (high-sensitive) probe
- remote “B” (low-sensitive) probe

1.2 FUNCTIONS

The instrument performs the following functions:

- measures, displays and prints (as an option):
 - dose rates (Sv/h)
 - counts of the probe, currently used for measurements
 - real time
 - warnings
- triggers the adjustable three-level alarms (with visual and audible signals) and records their occurrences;
- measures the dose increment (μSv) from the last daily periodic interval (daily reset, usually at 7:00);
- automatically prints out periodic reports on the dose increment, dose rates, alarms and functional warnings;
- measures and automatically prints out the total dose (μSv) of a longer time period (up to 1 year);
- allows listing or manual printouts of any displayed or stored data (dose rate in dose units or counts), including measuring parameters.
- optionally stores rainfall data, if ombrometer is connected to MFM

1.3 HIGHLIGHTS

- quick and simple assembly and initialization;
- automatic operation and easy management through user friendly interface with instructions shown on the LCD;
- predefined uncertainty of the measurements
- automatic optimization of the number of printouts;
- self-controlled operation with diagnostic and warning printouts;
- bypassing of mains power failure (approx. 2 days) with a built-in rechargeable battery or with an optional larger external 12 V battery
- linking to the communication network (modem + telephone line, radio - link) for the centralized on-line data collection and control (early warning system) over the built-in buffer memory and RS-232-C port;
- simple type-in reprogramming of code-protected measuring parameters (for example, when introducing a new measuring mode or when changing the probe calibration constants);
- fully compatible with previous MFM202A

1.4 MEASUREMENT PROCEDURE

EVENTS

Instrument counts pulses from probe A, probe B (and optionally ombrometer). There are two conditions that trigger the event:

- Number of preset pulses exceeded (after minimum event time)
- Maximum preset time of event exceeded

At that time dose rate is calculated for both probes. Value from A probe is stored and displayed, when probe A value is under “probe switch” level and “probe A over” level never occurred. Otherwise value from probe B is used. All events are stored in the list.

$$\text{DOSE RATE} = \frac{\text{probe counts} * \text{probe constant}}{\text{elapsed time} - \tau} - \text{bPar}$$

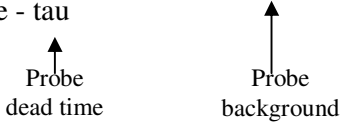

Dose rate calculation

RAIN LOGS

Rain logs are stored when remainder of division real time (in seconds) by preset rain interval time (in seconds) is 0. Counted pulses from ombrometer are multiplied by rain constant. Rain logs are stored in the list.

$$\text{RAIN VALUE} = \frac{\text{ombrometer counts} * \text{rain constant}}{\text{elapsed time}}$$

Rain value calculation

INTERVALS

Intervals are stored when *remainder of division* real time (in seconds) by preset interval time (in seconds) is 0. Dose increase is calculated and added to a daily dose. New counts and all events that belong to this interval are added. Optionally also rain logs are stored and summed up. All intervals are stored in list (bound to belonged events and rain logs).

$$\text{DOSE INCREASE} = \frac{\text{probe counts} * \text{probe constant} * \text{elapsed time}}{\text{elapsed time} - \tau} - \text{bPar}$$

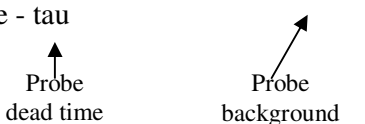

Dose increase calculation

2. TECHNICAL SPECIFICATIONS

RANGE OF DOSE RATES

- standard version with Probes A and B: 50 nSv/h ($50 \cdot 10^{-9}$ Sv/h) to 1000 mSv/h
- version with Probe A only: 50 nSv/h ($50 \cdot 10^{-9}$ Sv/h) to 600 μ Sv/h ($600 \cdot 10^{-6}$ Sv/h)

RANGE OF DOSES IN μ Sv

- limited to 5 digit display and one digit decade exponent (XXXXXXe+Y)

ENERGY RESPONSE OF PROBES

- linear in the energy interval from 60 keV to 1.3 MeV within $\pm 20\%$

LINEARITY

- deviation less than 7% within stated range

PROBES

- aluminum weather-proof housing with optional exchangeable plastic cap, weatherproof connector, operating temperature range - 40°C, +70°C, over-range output signal, audible indication of pulses; power supply: 12 V DC, internal high-voltage generator

DIAGNOSTICS

- programmed, with 10 malfunction warnings and their combinations

CONNECTION TO THE COMMUNICATIONS NETWORK

- over buffer memory and RS-232-C port

POWER SUPPLY

- 220 V 50Hz / 12V DC (option)
- from built-in rechargeable battery approx. 2 days

POWER CONSUMPTION

- without display illumination 0.6 W (12 V, 50 mA)

DIMENSIONS AND WEIGHT

- monitor: L 30 x W 20 x H 8 cm; 4.8 kg
- probe (1): L 31 cm x \varnothing 5 cm; 0.8 kg

The manufacturer reserves the right to change specifications without prior notice.



OPTIONS

- Extended length of probe cables up to a maximum of 150 m
- Probes of different dose rate ranges for special purposes
- Permanent external battery power supply unit
- Ombrometer for rainfall logging
- Modem
- Parallel printer

ACCESSORIES ON SPECIAL ORDER

- Two 1.6 m long aluminum poles for upright positioning and fixing Probes above ground with a minimum shading of ground
- Plastic expendable protective caps for Probes
- Polypropylene plastic tube $\varnothing=20$ mm for outdoor Probe cable protection

3. INSTALLATION

Before installation, check completeness of the shipping. Each MFM 203 set should contain:

RADIOLOGICAL MONITOR

- MFM 203 electronic unit
- GM probe “A”
- GM probe “B”
- Power (220 V) cord
- Connectors for probe-cables:
 - 2 PCs. SOURIAU, 6-pole, male (for probe-sides)
 - 1 PCs. microphone, 5-pole, male (for MFM side, probe “A”)
 - 1 PCs. microphone, 4-pole, male (for MFM side, probe “B”)
- Manual
- Calibration data for probes, if laboratory calibration is required

3.1 INSTALLATION OF GM PROBES

GM probes should be installed preferably with upper surface 1.3 m above the ground, on the opened surface. The next picture shows the principal mounting of the probes:

Care should be taken, that the metal rod, supporting the probes, is locally grounded, but the probes have **no electrical connection** to it. This means, that probes are grounded **only** through the cable shield to the common ground point at MFM 203.

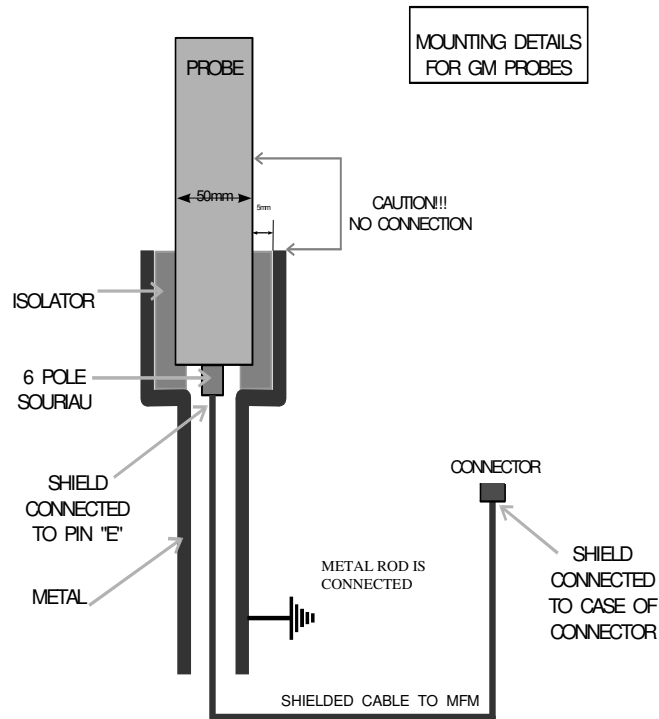

For each probe, user should assemble a cable from probe to the MFM 203 instrument. Connectors are provided as a part of MFM 203 installation set, cables should normally be provided by the user. Length of cables is installation dependent, but should not exceed 100 m. Standard 6-wire, 0.25 mm² shielded telephone or signal cables may be used. Care should be taken that shields are connected to pins “E” of 6-pole SOURIAU connectors on the probe side, and to the casings of microphone connectors (5-pole for probe “A”, 4-pole for probe “B”) on the instrument side.

Following pictures show pin connections for both probes:

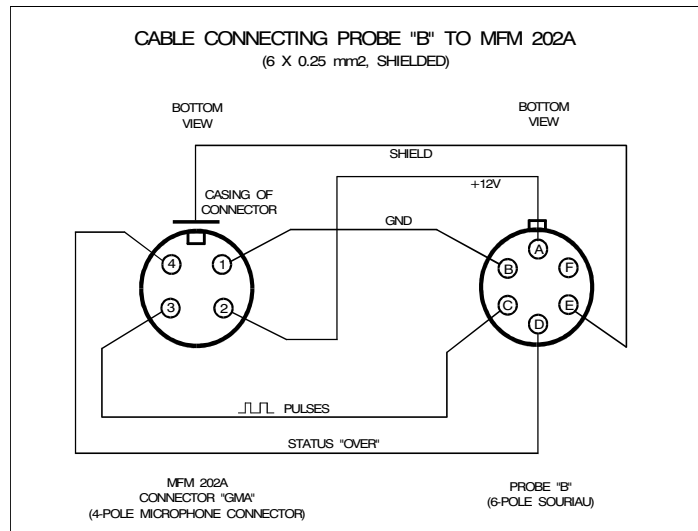
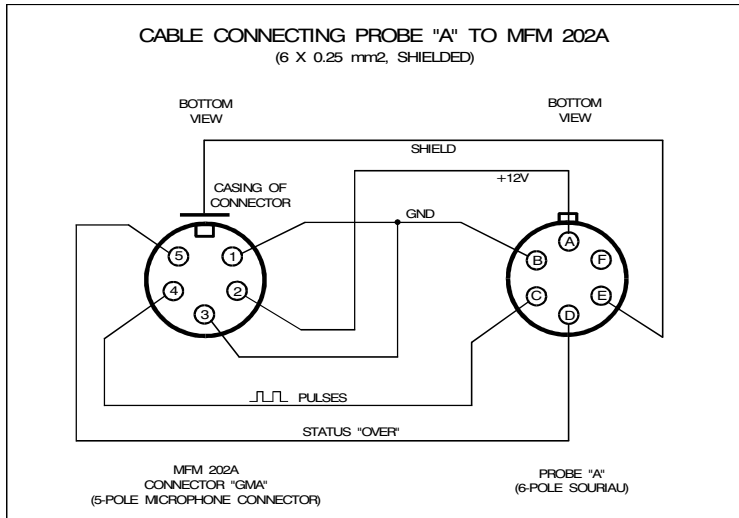

3.2 GROUNDING THE SYSTEM

The whole system should be grounded at one single point only. If user can provide a good local ground at the location site (highest resistance below 1 Ohm), the best way is to ground the system to this local ground:

- Disconnect and isolate the green/yellow wire in the 220 V plug on the mains cord of MFM 203. This should be done to break the ground loop from the local ground to the mains protective ground.
- Connect the “GND” screw at the bottom panel of MFM 203 to the local ground using at least 2.5 mm² copper wire. Be sure that all junctions have excellent contacts!
- Make sure that shields of cables to the probes are properly connected to the metal connector case on the MFM side and to the “E” pin on the probe side. Also, be sure that probes have no connections to their supports or to any other grounded object except to the MFM through cable shields.

If there is no possibility to provide local ground of adequate quality, system could be grounded to the mains protective ground. In this case, leave the mains cable **unchanged** (yellow/green wire should remain connected to the protective ground contact). Be sure that **there is protective ground connected** in the wall mains outlet. Make **no connections** to the GND screw on MFM 203!

Also in this case, probes should be grounded **only through the shields of their cables!**

3.3 CONNECTING CABLES

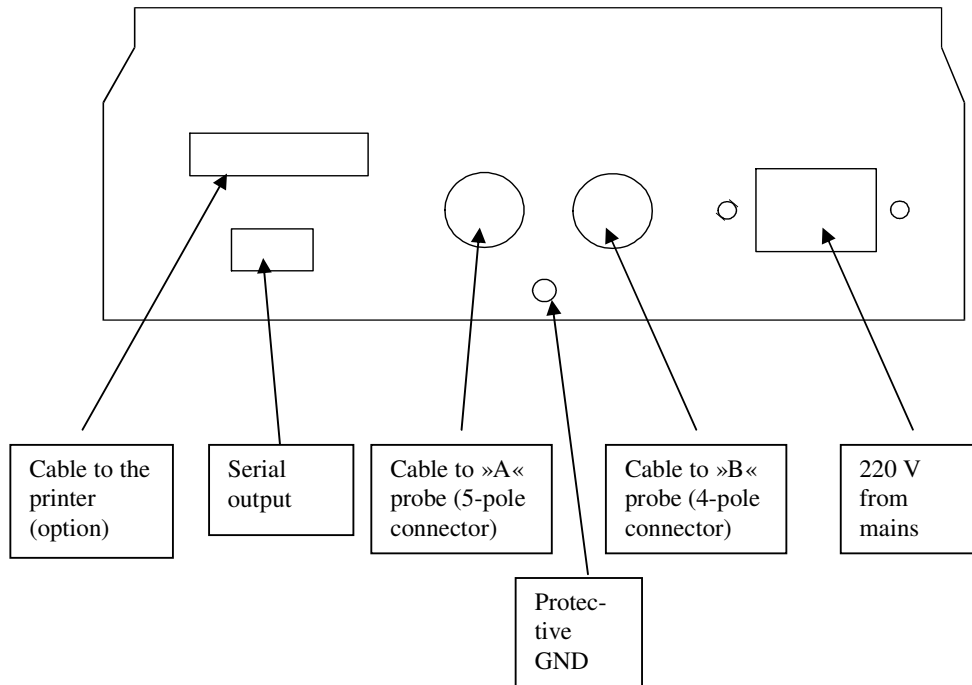

Connection of cables to MFM 203 (bottom view)

All cable connections to MFM 203 are shown on previous picture. While there is no danger of mismatching the connectors (all pin layouts are different), **maximum care should be taken that connectors for probes A and B are installed to the correct cables** (5-pole connector to the “A” probe and 4-pole to the “B” probe). Incorrect connection will cause erroneous dose calculations, because of the different calibration constants of the two GM probes.

Typical cable connections for the whole system are shown on the next scheme:

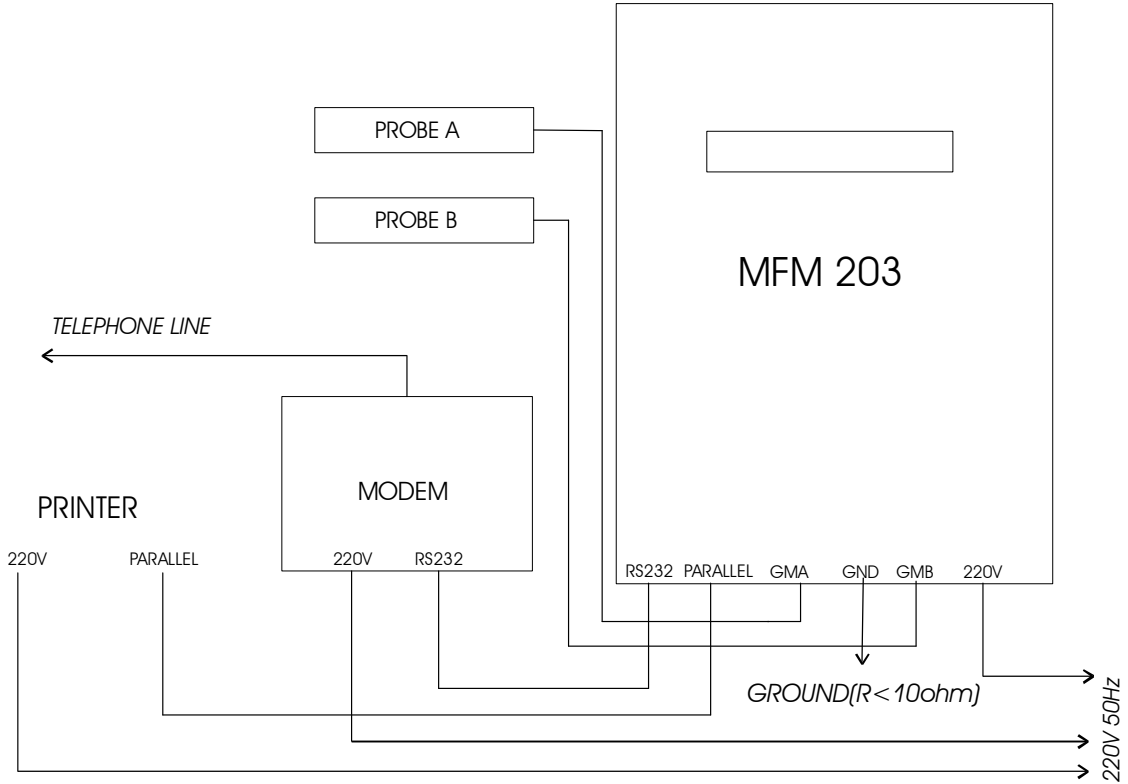

If local ground is connected (only when ground resistance is less than 10 ohm), disconnect isolate yellow-green (ground) wire inside 220V plug on power cord for MFM203!

4. OPERATING INSTRUCTIONS

4.1 INTERNAL POWER SUPPLIES

- In its standard version the instrument is powered from the 220 V mains. In the case of the mains power failure, the internal rechargeable battery provides an uninterrupted operation for approx. 2 days.
- Approximately 5 minutes before a complete discharge of the internal battery, blinking warning “**BATTERY LOW**” is displayed in the first line of *MEASUREMENT DISPLAY* and stored in the memory. After power recovery (i.e. activation of the printer) the warning and time of it are printed (if printer connected).
- In a case of total power failure (mains off, totally discharged internal battery), system stores data on the *dose increment* and *total dose*. After power recovery the instrument is **automatically turned on** and it continues to measure. Duration of the “*power off*” period may be determined indirectly later, by observing the stored data.
- The internal battery is charging every time when the power cord is plugged to main (220V), even if the instrument is turned off.
- If necessary, the instrument may be powered from a larger external 12 V battery. This option should be ordered separately.
- For maintaining the data, stored constants, and clock, an additional RAM - supporting 3.6 V lithium battery is installed in the instrument. This battery **should be replaced at least every 5 years** of operation (or if “*memory error*” is shown every time when the instrument is turned on). During the replacement, data are preserved if the instrument is turned on (powered by mains or internal / external rechargeable battery).

4.2 TURNING THE INSTRUMENT ON / OFF

- MFM 203 is powered on by pressing the yellow “ON/OFF” key. Note that instrument is automatically powered on every time mains power is recovered.

A successful initialization of the instrument displays “MEASUREMENT DISPLAY” with dose rates equal zero. Since the first result for DOSE RATE appears only after completion of the measuring cycle (typically after approximately 1.5 hour at the normal radiation background and standard parameters setting), the performances of probe A and probe B may be promptly checked by its counts.

Note: If initialization is not successful, message “Memory error” or “EPROM error” is displayed. In this case you should contact the maintenance personal.

- Pressing and holding the yellow “ON/OFF” key for a few seconds turns the instrument off.

4.3 USING KEYBOARD AND MENU

- The instrument has 16 colored keys: 11 green keys for numerals and decimal point, 1 yellow key for turning the instrument on and off, and 3 orange keys that are used for menu control (up, down, enter, clear),

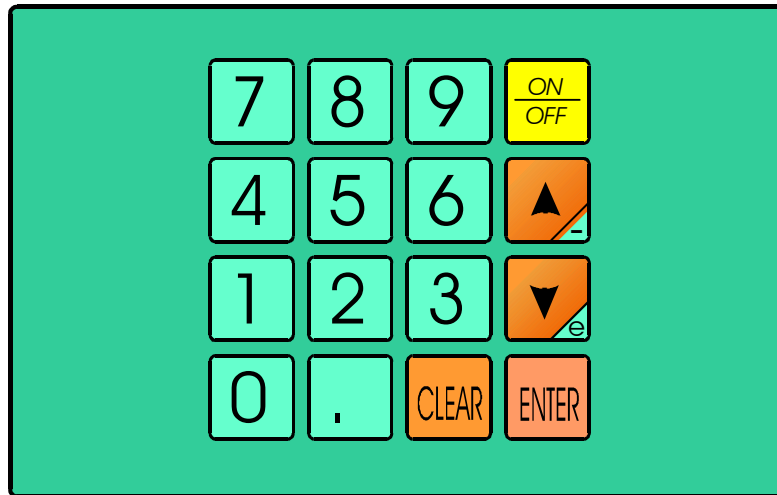

MFM 203 keyboard

- To enter into menu you have to press the ENTER key. The first line displayed shows the position in the menu tree. Second line shows the current option or the next menu level (the line starting with “>” char). You can move between options with UP and DOWN keys. If you want to confirm option or enter next menu level press ENTER key. To exit menu or options press CLEAR key.

Note: A minute after the last pressed key, instrument automatically exits the menu structure and returns to a “MEASURE DISPLAY”.

When inserting or modifying parameters the second line is started with “=>” char. The “UP” and “DOWN” key become “e” and “-“ char (to insert decimal and negative numbers). To stop parameter modification without saving it, clear string with “CLEAR” key. To save parameter, press “ENTER” key. Parameter will be saved only if it is in the correct format. Otherwise the instrument will display a warning.

- MENU OVERVIEW

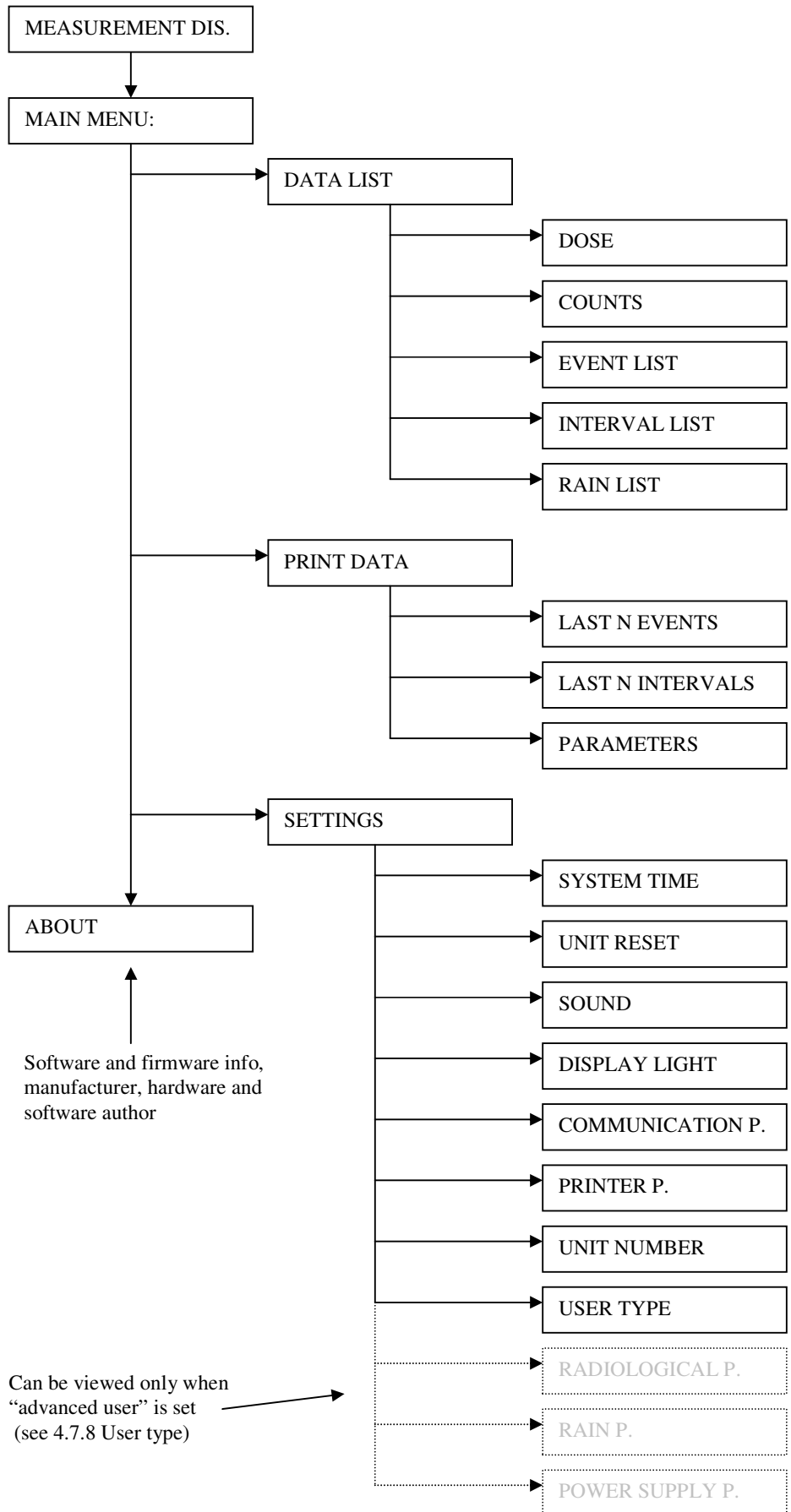

4.4 MEASUREMENT DISPLAY

During measurement instrument continuously displays the measured dose rate (first line), current used probe (A or B) and its counted pulses, current time, warnings and errors (second line).

Dose rate:	1.121e-07Sv/h
A:001252c	08:33:22

Typical measurement display

All errors and warnings detected during measurement are alternatively displayed in second line.

List of errors and warnings:

- BO probe B overflow (its counts are not valid)
- BZ probe B zero counts (probe B didn't count any pulse)
- AO probe A overflow (its counts are not valid)
- AZ probe A zero counts (probe A didn't count any pulse)
- AL probe A counts are under preset level
- A1 alarm level 1* is exceeded
- A2 alarm level 2* is exceeded
- A3 alarm level 3* is exceeded
- PE printer error (not connected, or printer is out of paper)

* Sound alarms (they are initialized when dose rate exceeds the user-set alarm levels) may be suppressed by pressing the "CLEAR" key. However, after muting, whenever one of the three alarm levels is reached or exceeded in any of the following measuring cycles, the sound alarm will be triggered again.

Dose rate:	1.121e-07Sv/h
AO A1 PE	

Measurement display with warnings

4.5 DATA LISTING

4.5.1 Dose

(Main menu->Data list->Dose)

You can browse three types of doses. Daily dose (daily dose increment), previous dose (dose of the previous day) and total dose (from the last reset). For each type of dose duration of measurement is also displayed. To switch between doses use “UP” and “DOWN” key.

- **DAILY DOSE**

Daily dose is recalculated at every (half-hour) interval time from daily reset time.

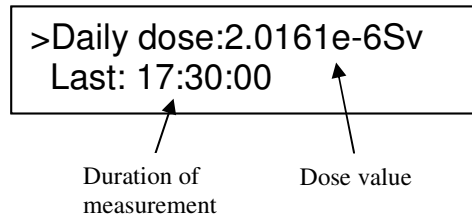

Daily dose display

- **PREVIOUS DAILY DOSE**

Previous daily dose is recalculated at daily reset time (typically at 7:00h).

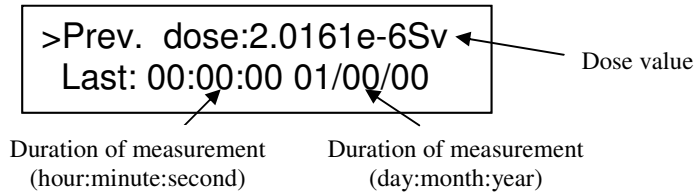

Previous day dose display

- **TOTAL DOSE**

Total dose is recalculated at every (half-hour) interval time from the last instrument reset.

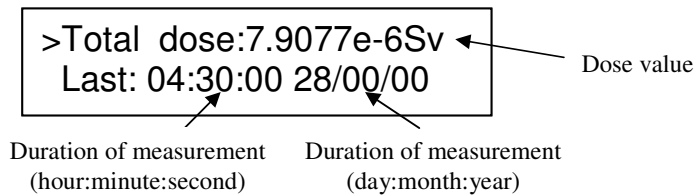

Total dose display

4.5.2 Counts

(Main menu->Data list->Counts)

Counting displays are used for the direct control of Probe A and Probe B. For reliability reasons, both Probes are always counting in parallel, the *live time* actually shows the time during which counts of the particular Probe were used for the calculation of dose quantities, i.e. the Probe was “active”. To switch between daily count and count rate use “UP” and “DOWN” key.

- **A/B COUNT RATE**

Displays counts per hour (c/h) of the “active” Probe used in calculation of the last dose increment (half hour interval) and the relative statistical uncertainty (\pm two standard deviations in %) of the measurement.

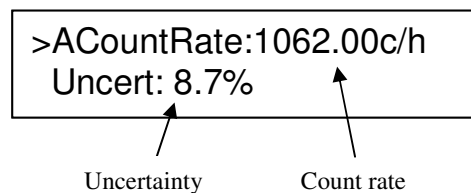

Count rate display of probe A

- **DAILY A/B COUNT**

Displays counts and live time in the time interval starting from the last daily reset time (typically at 7:00h). Note that only counts and live time that have been used in calculation are displayed.

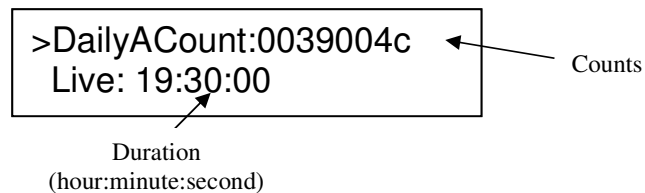

Daily count display of probe A

- **TOTAL A/B COUNT**

Displays counts and live time from the last instrument reset. Note that only counts and live time that has been used in calculation are displayed.

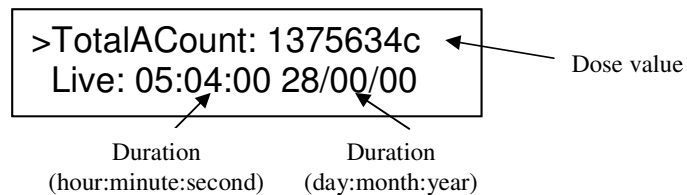

Total A/B count display

4.5.3 Event list

(Main menu->Data list->Event list)

When you want to browse event list, the instrument offers you to go to the end of list (last stored event) or to the beginning of list (first stored event). To browse between the events use “UP” and “DOWN” key. To stop listing, press “CLEAR” key.

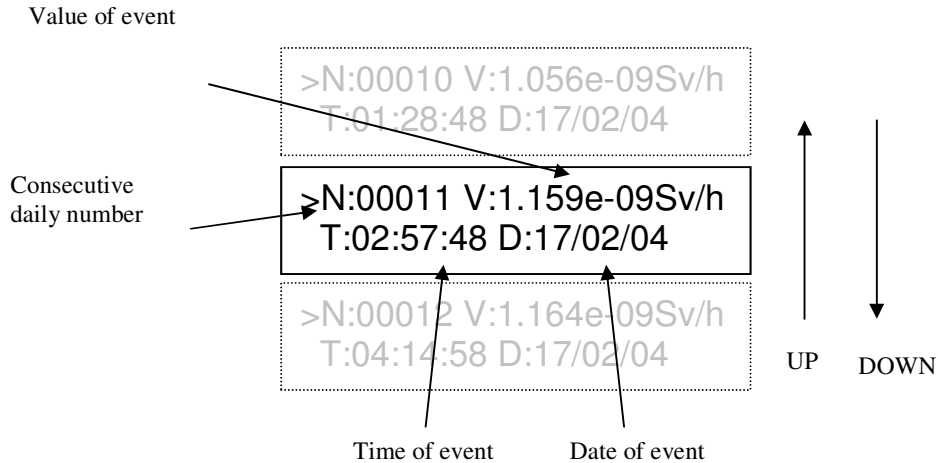

Typical event list

If you want more information about currently displayed event press “ENTER” key. To browse between the event properties use “UP” and “DOWN” key. To exit press “CLEAR” key.

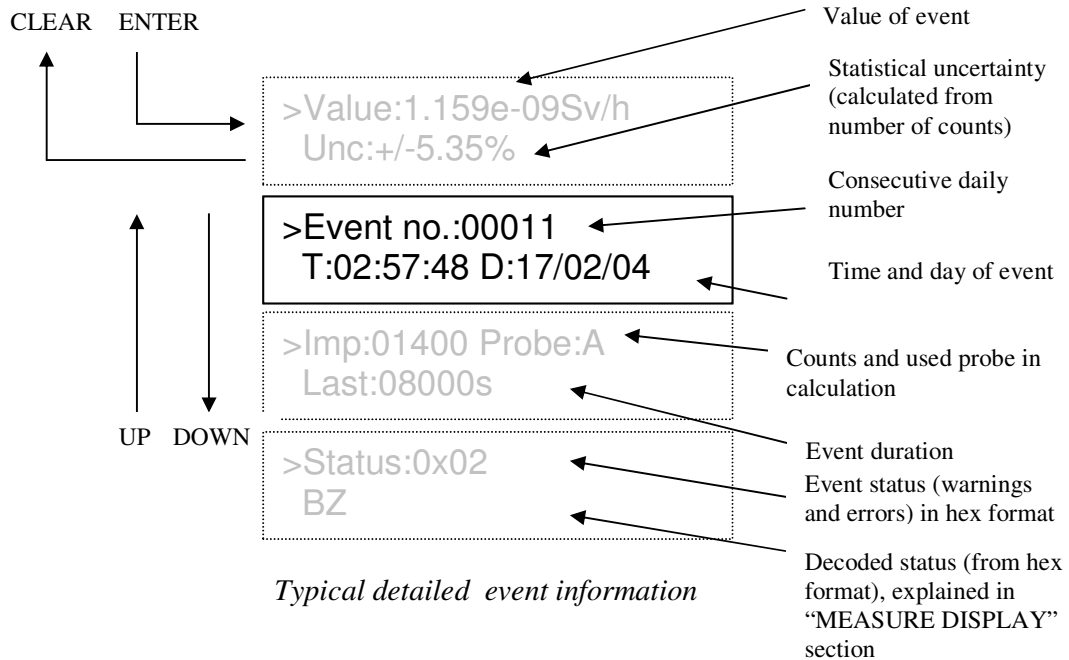

Typical detailed event information

In case that there is no event stored in database, “No event!” warning will be displayed.

The instrument will stop event browsing if database update occurred.

4.5.4 Interval list

(Main menu->Data list->Interval list)

When you want to browse interval list, the instrument offers you to go to the end of the list (last stored interval) or to the beginning of list (first stored interval). To browse other intervals use “UP” and “DOWN” key. To stop listing press “CLEAR” key.

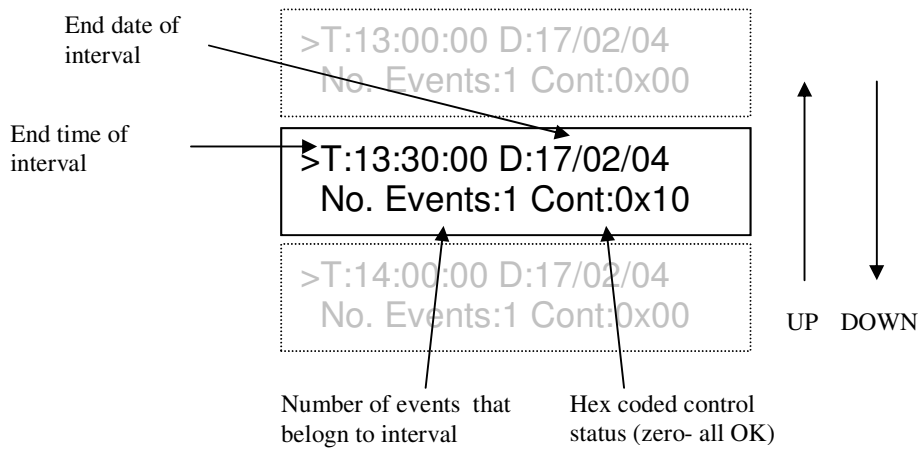

Typical interval list

If you want more information about currently displayed interval press “ENTER” key. To browse the interval’s properties use “UP” and “DOWN” key. To exit press “CLEAR” key.

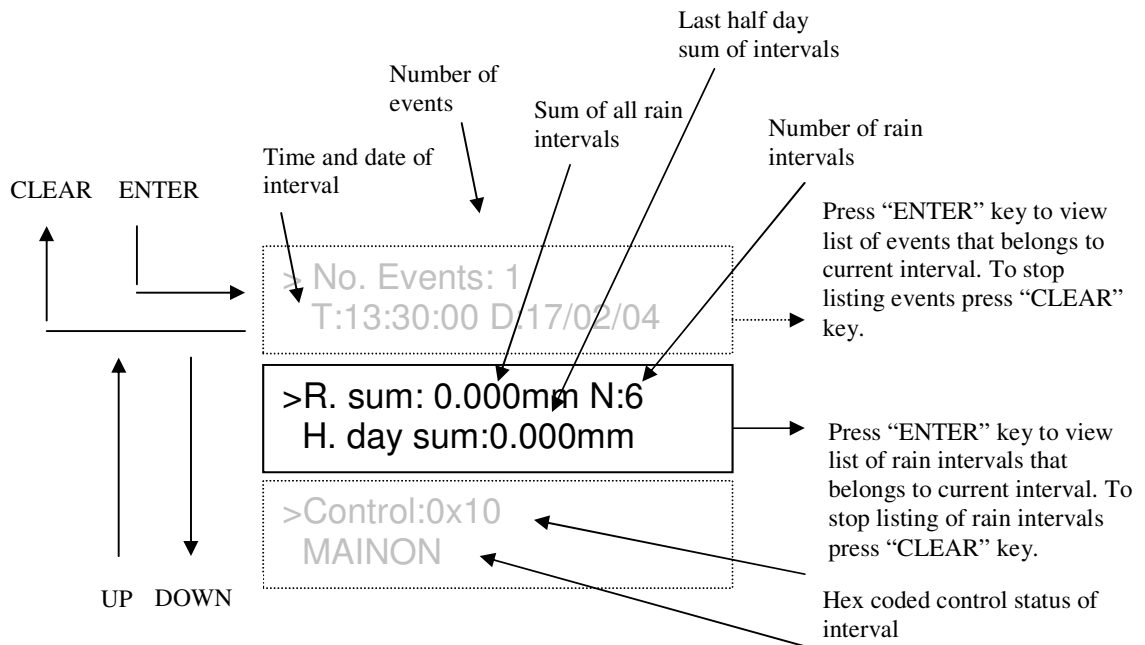

Typical detailed interval information

Decoded interval status



List of control status warnings:

- TSET time was set in interval
- MAINON mains power recovery occurred in interval
- LOWBAT low battery status occurred in interval
- POFF power off status occurred in interval
- ALARM alarm occurred in interval

In case that there is no interval stored in database, “No interval!” warning will be displayed.

Note, that frame with rain values will be present only if rain logging was enabled in interval.

The instrument will stop interval browsing if database update occurs.

4.5.3 Rain interval list

(Main menu->Data list->Rain list)

When you want to browse rain interval list, the instrument offers you to go at end of the list (last stored event) or to start of list (first stored event). To move between the events use “UP” and “DOWN” key. To stop listing press “CLEAR” key.

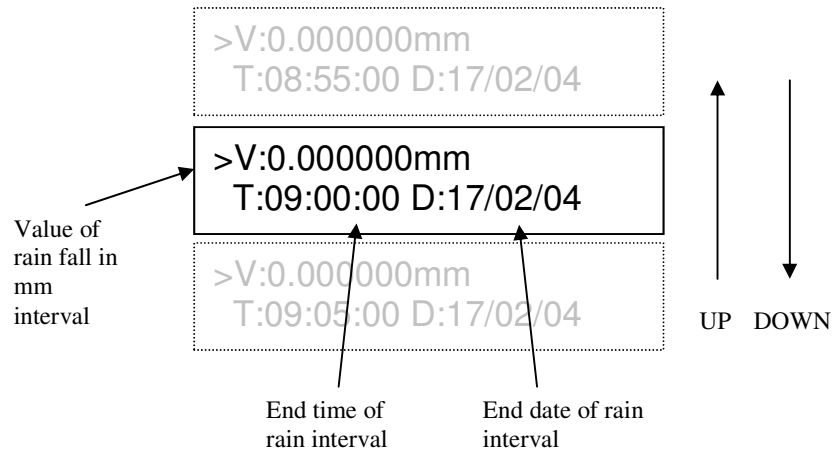

Typical rain interval list

In case that there is no rain interval stored in database, “No rain!” warning will be displayed.

The instrument will stop interval browsing if database update occurs.

4.6 MANUAL PRINTING OF DATA

If printer (parallel EPSON compatible) is present and connected, the instrument allows you to manually print stored data and parameters. Printer must have paper inserted and must be in »ON LINE« mode. Otherwise MFM will display »Printer busy« error. Note that also automatic printout can be set (*see 4.7.6 Printer parameters*).

4.6.1 Print last N events

(Main menu->Print data->Last N events)

If the printer is set correctly, you will be prompt to enter number (N) of last events you want to print. To print all stored events enter zero (0). In case that there is no event stored in database, “No event!” warning will be displayed.

4.6.2 Print last N intervals

(Main menu->Print data->Last N intervals)

If the printer is set correctly, you will be prompt to enter number (N) of last intervals you want to print. To print all stored intervals enter zero. Rain data that belongs to interval will be automatically added to the printout. In case that there is no interval stored in database, “No interval!” warning will be displayed.

4.6.3 Print parameters

(Main menu->Print data->Print parameters)

If the printer is set correctly, the instrument will print out all adjustable parameters.

4.7 CHANGING OF PARAMETERS

4.7.1 System time set

(Main menu->Settings->System time set)

First you will be prompted with current time. To change it write new time over old one. If cursor doesn't move to next digit, the inserted value is not valid for time format. You can go backward with "CLEAR" key. Press "ENTER" key when you are satisfied with the time.

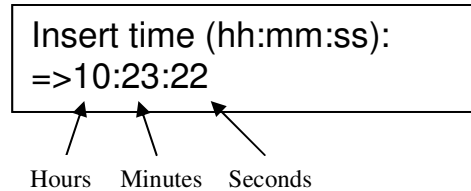

Time changing display

After that, you will be prompted with current date. To change it write new date over old one. If cursor doesn't move to next digit, the inserted value is not valid in date format. You can go backward with "CLEAR" key. Press "ENTER" key when you want to save new time and date. Notice "New time saved!" will be displayed, after successful time and date change.

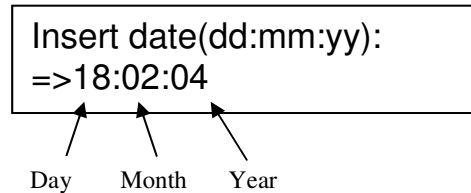

Date changing display

If you want to cancel new time and date insertion, just delete date and time with "CLEAR" key.

Both time and date must be inserted to change system time and date!

Note that time can also be set with KERMIT protocol through the serial communication.



4.7.2 System reset

(Main menu->Settings->Unit reset)

There are three types of reset. To move between them use “UP” and “DOWN” key. To select reset type press “ENTER” key.

- **Soft reset**

(Main menu->Settings->Unit reset->Soft reset)

Resets only current measurement. This type of reset is executed when the instrument is turned on. At the end of successful reset notice “Soft reseted!” is displayed.

- **Total reset**

(Main menu->Settings->Unit reset->Total reset)

Resets current measurement, reloads all parameters from EEPROM and clears all database. At the end of successful reset notice “Total reseted!” is displayed.

- **Load default settings**

(Main menu->Settings->Unit reset->Load default settings)

Resets current measurement, reloads all parameters from PROM, stores new parameters in EEPROM and clears all database. At the end of successful reset notice “Setting restored!” is displayed. Note that default probes constants are loaded (the measurement is in 10% accuracy).

Any errors (malfunction of EEPROM or MEMORY) occurred during reset are also displayed. In this case you should contact maintenance personal.

4.7.3 Sound setting

(Main menu->Settings->Sound)

To move between sound options use “UP” and “DOWN” key. To modify setting press “ENTER” key. After that you can enable or disable sound option with “UP” and “DOWN” keys. Confirm setting by pressing “ENTER” key. After successfully stored parameter “Parameter saved!” notice is displayed. To exit without settings changing, press “CLEAR” key.

- **Keyboard beep**
(Main menu->Settings->Sound->Keyboard beep)
Enabling this option, beeper beeps when any key is pressed.
- **Alarm**
(Main menu->Settings->Sound->Alarm)
Enabling this option, sound alarm is triggered when dose rate exceeds preset alarm value.
- **Probe A tick**
(Main menu->Settings->Sound->Probe A tick)
Enabling this option, beeper beeps at every pulse on probe A.
- **Probe B tick**
(Main menu->Settings->Sound->Probe B tick)
Enabling this option, beeper beeps at every pulse on probe B.
- **Event beep**
(Main menu->Settings->Sound->Event beep)
Enabling this option, beeper beeps when new event is stored into database.
- **Interval beep**
(Main menu->Settings->Sound->Interval beep)
Enabling this option, beeper beeps when new interval is stored into database.
- **Interval beep**
(Main menu->Settings->Sound->Daily reset beep)
Enabling this option, beeper beeps at daily reset.



4.7.4 Display back light settings

(Main menu->Settings->Display light)

To move between light options use “UP” and “DOWN” key. Confirm setting by pressing “ENTER” key. After light time was set, notice is displayed. To exit without settings changing, press “CLEAR” key.

- **Off**
(Main menu->Settings->Display light->Off)
Back light is always off. Appropriate when running on battery.
- **Automatic(10s)**
(Main menu->Settings->Display light->Automatic (10s))
Back light turns on when any key is pressed. Ten seconds after last pressed key, it is self-turned off.
- **Automatic(60)**
(Main menu->Settings->Display light->Automatic (60s))
Back light turns on when any key is pressed. Sixty seconds after last pressed key, it is self-turned off.
- **On**
(Main menu->Settings->Display light->On)
Back light is always on.

Note, that back light increases power consumption. It is not recommended to use it when running on battery.

4.7.5 Communication parameters

(Main menu->Settings->Communicaton)

To move between communication parameters use “UP” and “DOWN” key. To modify parameter press “ENTER” key. After modifying, confirm setting with “ENTER” key. After successful storing of parameter “Parameter saved!” notice is displayed. To exit without changing parameter press “CLEAR” key.

- **Protocol**
(Main menu->Settings->Communicaton->Protocol)
With this option desired protocol can be chosen. Currently only “KERMIT” protocol is implemented.
- **Modem**
(Main menu->Settings->Communicaton->Modem)
Enable this option when using modem for communication. Note that when this option is enabled instrument starts to use status lines on RS232 and occasionally initialization string is sent.
- **Pulse dial type**
(Main menu->Settings->Communicaton->Pulse dial type)
This option is used only when modem is used. If it is enabled, modem uses pulse dial type. Otherwise DTMF dial type is used.
- **Modem sound**
(Main menu->Settings->Communicaton->Modem sound)
Enabling this option, modem will be using its speaker when calling or receiving a call.
- **Call retries**
(Main menu->Settings->Communicaton->Call retries)
Number of call retries before canceling alarm call. Typically 3 retries are set.
- **Serial speed**
(Main menu->Settings->Communicaton->Serial speed)
Use “UP” and “DOWN” keys to choose desired serial RS232 communication speed. To confirm desired serial speed press “ENTER” key. If you want to exit without saving press “CLEAR” key. You can choose from 300bsp up 19200bps.
- **Alarm phone number**
(Main menu->Settings->Communicaton->Alarm phone number)
Insert desired phone number that instrument calls and transfers current event data when alarm occurs. Note that “Alarm notice” option must be enabled.
- **Alarm notice**
(Main menu->Settings->Communicaton->Alarm notice)
Enabling this option, instrument will automatically call to desired number and transfer data about current event when alarm occurs. If there is no modem, the instrument will simply transfer data through to serial port using “KERMIT” protocol in “client mode” when alarm occurs. Kermit must be in “server mode” on data terminal equipment side.

4.7.6 Printer parameters

(Main menu->Settings->Printer)

To move between printer parameters use “UP” and “DOWN” key. To modify parameter press “ENTER” key. After modifying, confirm setting with ”ENTER” key. After successful storing parameter “Parameter saved!” notice is displayed. To exit without changing parameter press “CLEAR” key.

- **Printer**
(Main menu->Settings->Printer parameters->Printer)
Set this option to on, when printer is connected to the instrument. Note, if this option is enabled and printer is not connected or correctly set, “printer error – PE” will be displayed (also in PE event status will be logged).
- **Event print**
(Main menu->Settings->Printer parameters->Event print)
Enabling this option, the instrument automatically prints out all event data every time when event is completed.
- **Interval print**
(Main menu->Settings->Printer parameters->Interval print)
Enabling this option, the instrument automatically prints out all interval data every time when interval is completed.
- **Reset print**
(Main menu->Settings->Printer parameters->Reset print)
Enabling this option, the instrument automatically prints out time and date every time the instrument is reset.
- **Mains on print**
(Main menu->Settings->Printer parameters->MainsOn print)
Enabling this option, the instrument automatically prints out time and date every time when mains power is recovered.
- **Daily reset print**
(Main menu->Settings->Printer parameters->Daily reset print)
Enabling this option, the instrument automatically prints out daily dose report at daily reset.
- **Time out**
(Main menu->Settings->Printer parameters->Time out)
Number of seconds for a delay after busy signal on printer is detected and “Printer error” is displayed. Note, for a slow this number should be at least 30 seconds.

4.7.7 Unit number

(Main menu->Settings->Unit number)

This unique number is used for identification when MFM is used in a network (transferred “PG” and “TG” files, *see 4.8 DATA TRANSMISSION*). After modifying number, confirm setting with ”ENTER” key. After successful storing number “Parameter saved!” notice is displayed. To exit without changing number press “CLEAR” key.

The number must be inserted in decimal (0-65535) format.

Note that number is presented in hex format (16bit) later.

4.7.8 User type

(Main menu->Settings->User type)

Instrument supports two types of users, “normal” and “advance” user. Normal user has reduced menu (some options are disabled, *see 4.3 USING KEYBOARD AND MENU*) to prevent unauthorized users modifying important parameters.

For “normal user type” insert 0 (zero). To go in “advanced user mode” insert “88”. After successful changed user type, notice about user type is displayed.

Warning: Changing parameters to wrong values in advanced user menu can cause malfunction of the instrument.

4.7.9 Radiological parameters

(Main menu->Settings->Radiological parameters)

To move between radiological parameters use “UP” and “DOWN” key. To modify parameter press “ENTER” key. After modifying, confirm setting with ”ENTER” key. After successful storing of the parameter “Parameter saved!” notice is displayed. To exit without changing parameter press “CLEAR” key

- **Preset count of probe A**
(Main menu->Settings->Radiological parameters ->PresetCountA)
Number of probe A counts that trigger the event. If zero value is inserted, this option is disabled (no event is triggered).
Note: Event can also be triggered by exceeded event time or probe B counts, if occurs prior to this.
- **Preset count of probe B**
(Main menu->Settings->Radiological parameters ->PresetCountB)
Number of probe B counts that trigger the event. If zero value is inserted, this option is disabled (no event is triggered).
Note: Event can be also triggered by exceeded event time or probe A counts, if occurs prior to this.
- **Probe B**
(Main menu->Settings->Radiological parameters ->ProbeB)
This option must be enabled when both probes are connected to the instrument. If there is no probe B connected, disable this option to avoid “probe B zero counts – BZ” warning.
- **Minimal Event Time**
(Main menu->Settings->Radiological parameters ->MinEventTime)
Number of minimal interval time (in seconds) before event can be triggered by A or B probe. If value zero is inserted, this option is disabled (no minimal event time limit). Typically this value is 300 seconds.
- **Maximal Event Time**
(Main menu->Settings->Radiological parameters ->MaxEventTime)
Number of seconds before event is triggered. If value zero is inserted, this option is disabled (no event is triggered by time limit). Typically this value is 8000 seconds. *Note: Event can be also triggered by probe A or B counts, if occurs prior to this.*
- **Interval Time**
(Main menu->Settings->Radiological parameters ->IntervalTime)
Number of seconds between intervals. If value zero is inserted, no interval is triggered. *Note that interval is triggered by module of seconds and not by duration!* Typically this value is 1800 seconds (half hour).
- **Alarm 1 level**
(Main menu->Settings->Radiological parameters->Alarm1)
Level of alarm 1 in Sv/h. Typically this value is 2.0e-7 Sv/h.
- **Alarm 2 level**
(Main menu->Settings->Radiological parameters->Alarm2)
Level of alarm 2 in Sv/h. Typically this value is 2.0e-4 Sv/h.

- **Minimal probe A count**
(Main menu->Settings->Radiological parameters->Alarm1)
Level of minimal probe A counts per hour before “probe A low counts-AL” warning is triggered. Typically this value is 560 counts/hour.
- **Probe A constant**
(Main menu->Settings->Radiological parameters->ConstA)
Probe A constant that is used in dose calculations. Note that if default values is used, the results are within +/-10%. Insert constant from probe calibration certificate for better accuracy.
- **Probe B constant**
(Main menu->Settings->Radiological parameters->ConstB)
Probe B constant that is used in dose calculations. Note that if default values is used, the results are within +/-10%. Insert constant from probe calibration certificate for better accuracy.
- **TAU A constant**
(Main menu->Settings->Radiological parameters->TauA)
Probe A dead time. Typically this value is set to zero.
- **TAU B constant**
(Main menu->Settings->Radiological parameters->TauB)
Probe B dead time. Typically this value is set to zero.
- **BPAR A constant**
(Main menu->Settings->Radiological parameters->bParA)
Probe A background. Typically this value is set to zero.
- **BPAR B constant**
(Main menu->Settings->Radiological parameters->bParB)
Probe B background. Typically this value is set to zero.
- **Daily Reset Time constant**
(Main menu->Settings->Radiological parameters->DailyResetTime)
Time that triggers daily rest. To change it writes new time through old. If cursor doesn't move to next digit, the inserted value is not valid in time format. You can go backward with “CLEAR” key. Press “ENTER” key when you are satisfied with time.
Typically is set to 7:00.
- **Probe A/B level**
(Main menu->Settings->Radiological parameters->A/BLevel)
Level in Sv/h when instrument switches from probe B to probe A.
- **Probe A/B switch hysteresis factor**
(Main menu->Settings->Radiological parameters->A/BLevelH)
Number $h \leq 1$ is a factor which reduces the level at which calculations are transferred from Probe B back to the Probe A – (e.g. $h = 0.90$ means that the B-A transfer is made at $200e-6 \times 0.9 = 180e-6$ Sv/h).
- **Daily Probe Reset**
(Main menu->Settings->Radiological parameters->DailyProbeReset)
Enabling this option, all counts from probes will be reseted to zero at daily reset time and the event number will be counter from 0 on.

4.7.10 Rain parameters

(Main menu->Settings->Rain parameters)

To move between rain parameters use “UP” and “DOWN” key. To modify parameter press “ENTER” key. After modifying, confirm setting with ”ENTER” key. After successful storing parameter “Parameter saved!” notice is displayed. To exit without changing parameter press “CLEAR” key.

- **Rain logging**

(Main menu->Settings-> Rain parameters ->Rain logging)

Enable this option only when an ambrometer is connected to the instrument. If there is no ambrometer connected disable this option, to expand database place and to avoid unnecessary “P120” parameters in “PG” files.

- **Rain constant**

(Main menu->Settings-> Rain parameters ->Rain constant)

ambrometer constant used in rainfall calculations. Expressed in millimeters per pulse.

- **Rain interval**

(Main menu->Settings-> Rain parameters ->Rain interval)

Length of rain interval in seconds. Typically this value is 300 seconds.

4.7.11 Power supply parameters

(Main menu->Settings->Power supply)

To move between power supply parameters use “UP” and “DOWN” key. To modify parameter press “ENTER” key. After modifying, confirm setting with ”ENTER” key. After successful storing parameter “Parameter saved!” notice is displayed. To exit without changing parameter press “CLEAR” key.

- **Alarm 1 voltage**

(Main menu->Settings-> Power supply ->Alarm1Voltage)

Level of battery voltage when “Battery low” warning is displayed. For internal battery set only, this value should be 11.5V.

- **Alarm 2 voltage**

(Main menu->Settings-> Power supply ->Alarm2Voltage)

Level of battery voltage when the instrument shuts down itself. Typically this value is set to 10.8V. **Warning: Setting this value lower than 10.0V can cause permanent damage of battery.**

4.8 DATA TRANSMISSION

Data are transmitted from MFM 203 using standard KERMIT protocol. Four types of files may be transmitted: time, instant data, half-hour data and parameters.

4.8.1 Connection

- *Serial link cable*
Connect your computer and instrument using serial link cable (RS-232). Connection is established.
- *Modem*
First configure modem to use the auto answer mode. It is also possible to use instrument “modem initialization” string to do it (*see 4.8.5 Transmission of Parameters*). Connect instrument with modem serial cable. At the end connect modem to a phone line. After external call to a modem, connection is established.

Note, that the same serial speed must be set on both sides (instrument and data terminal device), also communication setting should be set:

- *8 BITS,*
- *1 STOP BIT,*
- *NO PARITY.*

All files are in ASCII format.



4.8.2 Instant data

Two conditions must be fulfilled prior to receiving instant data:

- Instrument should pass first (usually ½ h) interval (time XX:00 or XX:30).
- First event (dose-rate calculation) must be completed.

After these two conditions are true, user can call for instant data as follows:

KERMIT COMMAND: *GET TG*

As instant data, data from the last completed event are returned, in the following data format:

T163 - radioactivity

Transmission date
Transmission time
Station name
Last measured dose rate
Uncertainty
Active probe (A or B)
Event number
Date of event
Time of event
Current status
Current probe A INCREMENT
Probe A LIVE TIME
Current probe B INCREMENT
Probe B LIVE TIME
Control

P120 – rain data (if rain logging is enabled)

Last rain interval value (in mm)

Tabulators separate each value; EOF is placed at the end.

4.8.3 Last interval data

KERMIT COMMAND: *GET PG*

For format description see 4.8.4 Any Stored data interval.

4.8.4 Any stored interval data

KERMIT COMMAND: *GET PGhhmmDD.MM*

Where:

hh are hours of interval
mm are minutes of interval
DD is day of interval
MM is month of interval

Example: command GET PG203012.03E returns data from 12th of March at 8:30 PM.

P163 - radioactivity

Transmission date
Transmission time
Time of (typ. 30 minutes) interval
Date of (typ. 30 minutes) interval
Number of transferred events
Dose rate 1
Uncertainty 1
Active probe (A or B) 1
Event number 1
Date of event 1
Time of event 1
Status 1
Dose rate 2
Uncertainty 2
Active probe (A or B) 2
Event number 2
Time of event 2
Status 2
Dose rate 3
Uncertainty 3
Active probe (A or B) 3
Event number 3
Time of event 3
Status 3
Dose rate 4
Uncertainty 4
Active probe (A or B) 4
Event number 4

Time of event 4
Status 4
Dose rate 5
Uncertainty 5
Active probe (A or B) 5
Event number 5
Time of event 5
Status 5
Dose rate 6
Uncertainty 6
Active probe (A or B) 6
Event number 6
Time of event 6
Status 6
Dose of the current day
Starting time of day dose counting
Dose of the previous day
30 minutes interval control

P120 - rain data (if rain logging is enabled)

Sum of all rain logs in (typ. half hour) interval in mm
Rain logs 1 value (typ. 1 st five minutes sum) in mm
Rain logs 2 value (typ. 2 nd five minutes sum) in mm
Rain logs 3 value (typ. 3 rd five minutes sum) in mm
Rain logs 4 value (typ. 4 th minutes sum) in mm
Rain logs 5 value (typ. 5 th minutes sum) in mm
Rain logs 6 value (typ. 6 th minutes sum) in mm

Tabulators separate each value; EOF is placed at the end.

Typically there is only one event (and maximum six) per interval with normal default radiological settings. It is also possible to have more than six events per interval if radiological (or rain) settings are different as default!

4.8.5 Parameters

KERMIT COMMAND: *GET PARAM*

Preset counts of probe A
Preset counts of probe B
Probe B (1=ON, 0=OFF)
Minimal event time
Maximal event time
Interval length time
Alarm 1 level
Alarm 2 level
Minimal count A level
Probe A constant
Probe B constant
TauA constant
TauB constant
BParA constant
BParB constant
Daily Reset time (in seconds from midnight)
Daily probes reset (1=ON, 0=OFF)
Modem (1=ON, 0=OFF)
Protocol (0=Kermit)
Pulse dial type (1=ON, 0=OFF)
Modem sound (1=ON, 0=OFF)
Call retries
Alarm notice call (1=ON, 0=OFF)
Alarm phone number string (14 character max.)
Modem initialization string (10 character max.)
Serial speed(0=300,1=600,2=1200, 3=2400, 4=4800,5=9600, 6=19200)
Sound settings (bit coded)
Light set (0=Off,255=On,10=auto. 10s, 60=auto. 60s)
Printer set (bit coded)
Printer timeout (in seconds)
Printer initialization string (8 character max.)
Station identification number
Battery alarm 1 voltage
Battery alarm 2 voltage
Detector divide ratio
Rain logging (1=ON, 0=OFF)
Rain interval time (in seconds)
Rain constant

Tabulators separate each value; EOF is placed at the end.



There is also a possibility to upload all parameters from “PARAM” file, with following command:

KERMIT COMMAND: *SEND PARAM*

4.8.6 Time

KERMIT COMMAND: *GET TIME*

T – time format

Day/Month/Year

Hour/Minute/Second

Tabulators separate each value; EOF is placed at the end.

It is also possible to set new time sending special “C” file with command:

KERMIT COMMAND: *SEND C*

Content of “C” file:

NUP(hhmmDDMMYY)

Where:

ss seconds
hh hours
mm minutes
DD day
MM month
YY year

LF and CR are placed at the end.

4.8.7 Internal log file

KERMIT COMMAND: **GET LOG**

Mfm will send you a complete activity log file. It should be used only for debugging.